



# Heavy Duty Concrete Crushers



*Leaders in Quality,  
Service & Reliability*

Ideal for severe applications, recycling,  
and demolition of:

- Road
- Beds
- Pillars
- Rebar
- Buildings
- Floors
- Bridges
- Foundations



The  
"Cruncher"

Concrete's  
Worst  
Enemy



# Heavy Duty Concrete Crushers

Machine Weight lb (T)	Model	Weight lb (kg)	Approx. Opening in (mm)	Max Conc. Thickness in (mm)	Jaw Depth in (mm)	Lower Jaw Width in (mm)
14,000 - 25,000 (6.4 - 11.3)	GT20*	827 (375)	23 (584)	13 (330)	16 (406)	13 (330)
25,000 - 40,000 (11.3 - 18.1)	GT30*	1,497 (679)	28 (711)	14 (356)	21 (533)	15 (381)
40,000 - 50,000 (18.1 - 22.7)	GT40-RJ	2,253 (1,022)	30 (762)	24 (610)	25 (635)	16 (406)
50,000 - 65,000 (22.7 - 29.7)	GT60-RJ	2,460 (1,116)	36 (914)	30 (762)	27 (686)	16 (406)
65,000 - 80,000 (29.7 - 36.3)	GT80-RJ	3,739 (1,696)	42 (1,067)	36 (914)	29 (737)	21 (533)
80,000 - 115,000 (36.3 - 52.2)	GT100-RJ	4,872 (2,210)	48 (1,219)	42 (1,067)	35 (889)	30 (762)
115,000 - 180,000 (52.2 - 81.6)	GT120*	7,688 (3,487)	54 (1,372)	48 (1,219)	40 (1,016)	41 (1,041)

\*Not available with replaceable jaws

### Performance Features:

- Utilizes the excavator's hydraulic forces to crush concrete and cut rebar
- No additional hydraulics required
- Made of high strength, abrasion resistant steel
- Wear resistant alloy pivot bearings
- Fitted with replaceable shear blades for cutting rebar
- Available with pin-on replaceable jaws as standard
- Heavy torque tubes of 70,000 PSI minimum yield steel included

### Options:

- Additional base plates for mounting to different machines

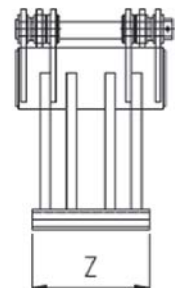
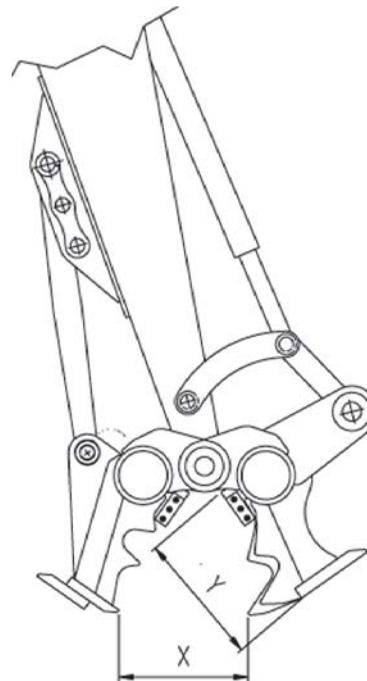

Geith  
1293 Glenway Drive  
Statesville, NC 28625  
T: (866) 472-4373  
F: (866) 472-4950

ussales@geith.com  
www.geith.com

